

DUROLL[®]

OPERATING MANUAL

AHD216

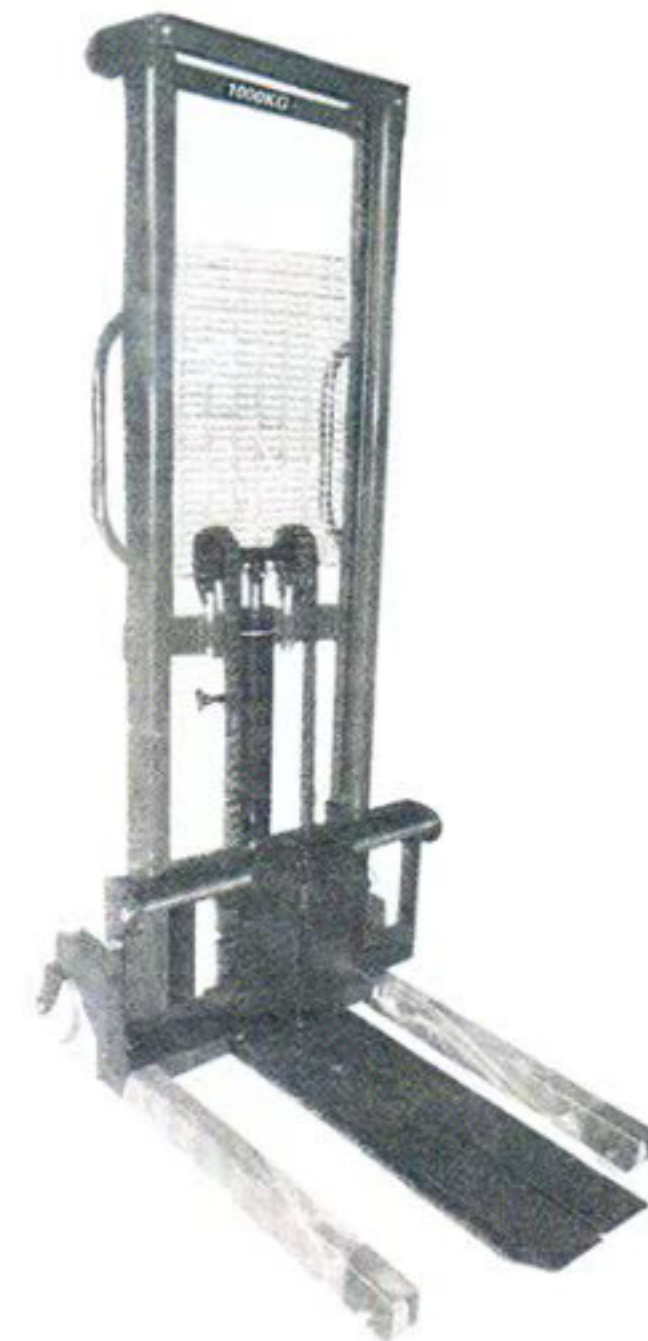

3.8 Don't surcharge.

3.9 The goods should be placed on forks uniformly and never overload.

3.10 Heavy should not be allowed to remain on the forks for a long time after operation is over.

3.11 The stacker is intended for use on flat and hard ground. During driving the forks must not be lifted more than maximum 300mm.

3.12 Forbid standing under the stacker forks.

3.13 When stacking with lifted forks, driving should be slow and over the shortest possible distance due to the stability.

3.14 Do not operate those not approved parts!

3.15 Don't try repairing the stackers without training.

4. MAINTENANCE:

4.1 HYDRAULIC OIL:

Please check the hydraulic oil per six months. The hydraulic oil brand No.:ISOVG32. The campaign viscosity is 32cst in 40°C.

The hydraulic oil needed by the oil pump is about 3.0 liter. The ISO oil quality standard shall be complied with under which ISOVG32 oil be used at -5~40°C and low at an ambient temperature of temperature working oil -35~-5°C.

4.2 DAILY CHECK & MAINTENANCE:

Everyday routine examination is necessary for solving the abnormal operations at sight. Don't use the troubled stacker for the sake of lubricated by pump oil every three months, and see to that the wheels and axles are not in tangled by threads or other materials. All the wheels shall runs smoothly.

4.3 The user of the stacker should spend a few minutes every week on cleaning. special attention should be paid to the wheels and axles. see if there is thread, rags and the like blocked on.

4.4 Lubricate the lifting chain. If the stacker is working in dust-laden circumstances, it should occasionally be cleaned with all oil impregnated towel. Check the chain for wear. Check and tighten possible loose screw and nuts.

5. POSSIBLE FAILURES AND SOLUTIONS.

No.	Failure	Causes	Solution
1.	Insufficient lifting	The hydraulic oil is Not adequate.	Add appropriate filtered working oil
2.	The forks do not lift.	1. viscosity of working oil is too high or the working oil or not added enough. 2. impurity in oil. 3. abnormal of unloading device.	1. replace the working oil. 2. remove the impurities in the oil circuit and replace the oil. 3. re-adjust the unloading device.
3.	The forks do not lower after rising. parts.	1. abnormal in unloading devices. 2. deform and damage in parts.	1. re-adjusting the unloading device. 2. replace the deformed and damaged parts.
4.	Leakage of hydraulic	1. failure of oil seal. 2. light break or erosion on the surfaces of one or two parts. 3. relax in joints.	1. replace the seal. 2. replace the damaged parts. 3. tighten the joints.

6.CTY SERIES HAND STACK ANALYSIS DRAWING & PARTS:

No:	Description	Quantity	No:	Description	Quantity
101	Control pole	1	210	Ball	1
102	Paddal limit	1	211	Valve spring	1
103	Bolt	1	212	Ball	1
104	Paddal	1	213	Valve spring	1
105	Nut	1	214	Pad ring	1
106	Cylinder pin	3	215	Ball	1
107	Slip bearing	2	216	Pump	1
108	Roller wheel	1	217	Screw ring	1
109	Roller wheel axle	1	218	"o" ring	1
110	Fixture axle	1	219	"o" ring	1
111	Slip bearing	2	220	Dust ring	1
			221	Cylinder cap	1
201	Cylinder pin	1	222	Spring retaining ring	2
202	Pump piston rod	1	223	Bearing	2
203	Washer	1	224	Chain wheel	2
204	Pump piston rod spring	1	225	Orifice spring ring	2
205	Dust ring	1	226	Chain wheel frame	1
206	Screw ring	1	227	Poston rod	1
207	Handle 1	1			
208	"o" ring	2			
209	Ball	1			

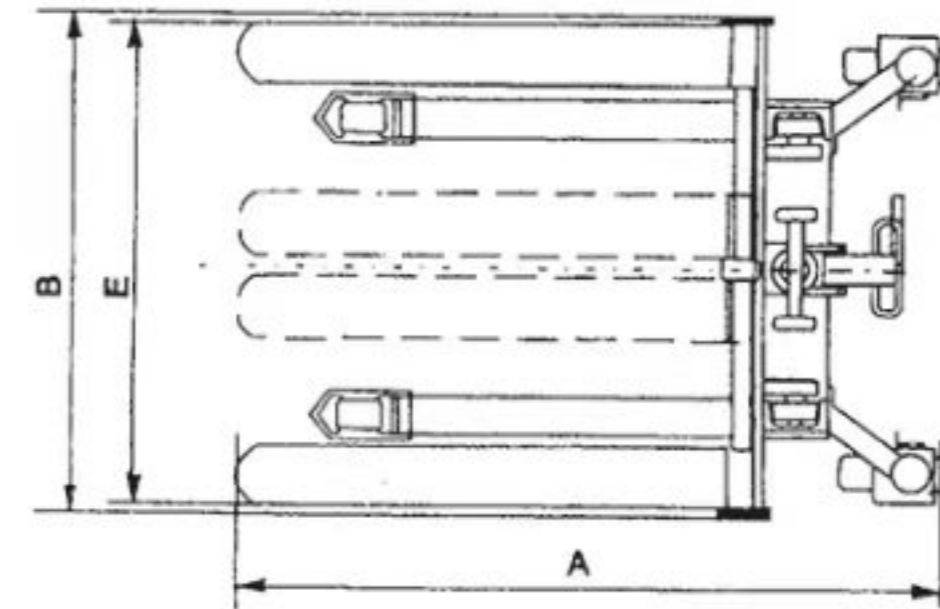
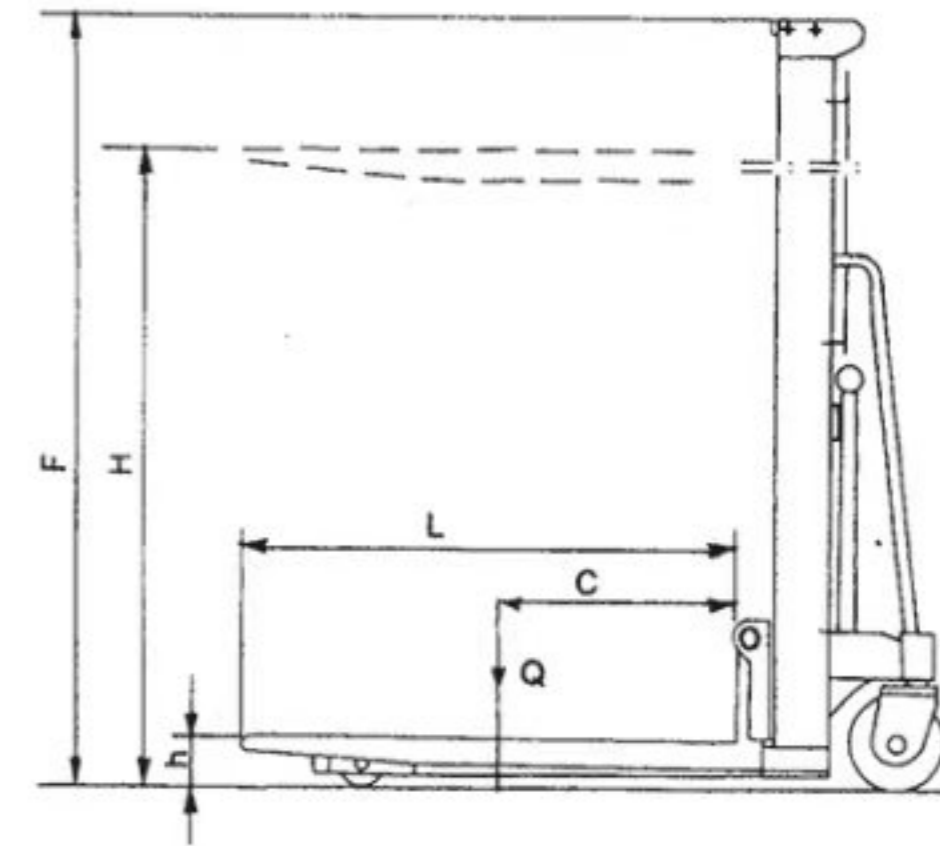
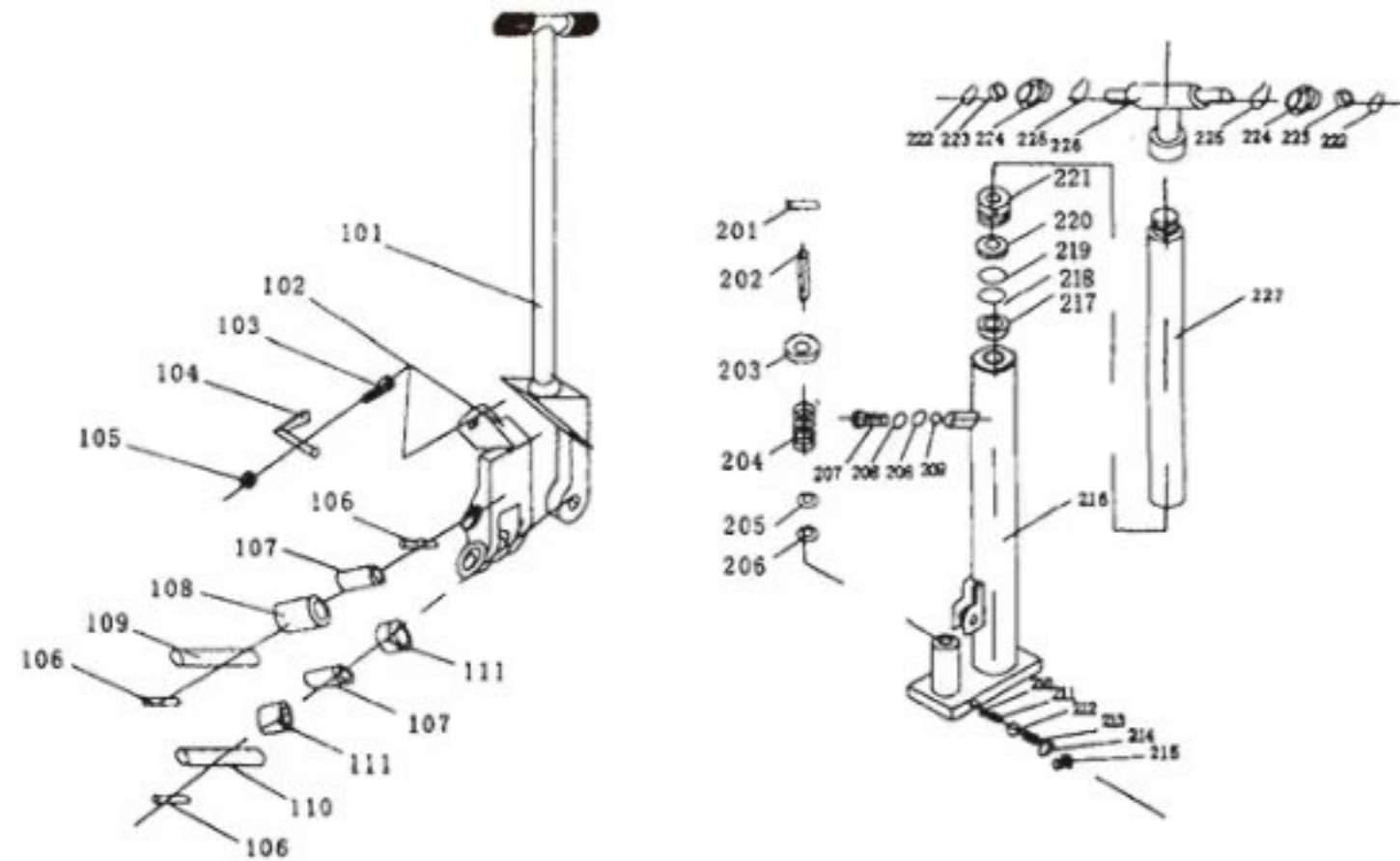

3. OPERATION GUIDANCE:

- 3.1 Operator must be understand the instruction and all the warning indicate before using the stacker.
- 3.2 Don't use the stacker before training & Anthorization.
- 3.3 It must be checked the stacker before using the stacker. In particular such as attention the stacker wheel. Handle. Rolier wheel. Stacker frame.
- 3.4 Don't use the stacker on the descent ground.
- 3.5 Don't loading-person under the forks.
- 3.6 The operator had better wear the glove and pull on re-glide shoes before used the stacker.
- 3.7 Others must be distance the stacker more than 600 millimetre.

CBY-ACOil pump rear wheel parts

Serial number	name	quantity	Serial number	name	quantity
301	Spring gland	1	322	Plunger spring	1
302	spring	1	323	Item bar	1
303	Pump core	1	324	Plunger seal	1
304	Dust ring	1	325	Copper nut	1
305	Y type seal	1	326	O ring	1
306	Ball ball	1	327	Groove flat end screw	1
307	body	1	328	nut	1
308	Valve core	1	329	Elastic cylindrical pin	1
309	Valve core spring	1	330	Foot control arm	1
310	Big sealing washer	2	331	cylinder	1
311	plug	1	332	Small seal washer	2
312	Dust cover	2	333	Oil plug	2
313	Shaft with ring	2	334	Spring limit lever	1
314	6204 bearing	4	335	Y type seal	1
315	Rear wheel	2	336	Cover O ring	1
316	Elastic cylindrical pin	1	337	cover	1
317	Elastic cylindrical pin	2	338	O ring	1
318	Supporting plate	1	339	Piston rod dust ring	1
319	Shaft with ring	1	340	Piston rod	1
320	Thrust ball bearing	1	341	ball	1
321	Shaft after	1			

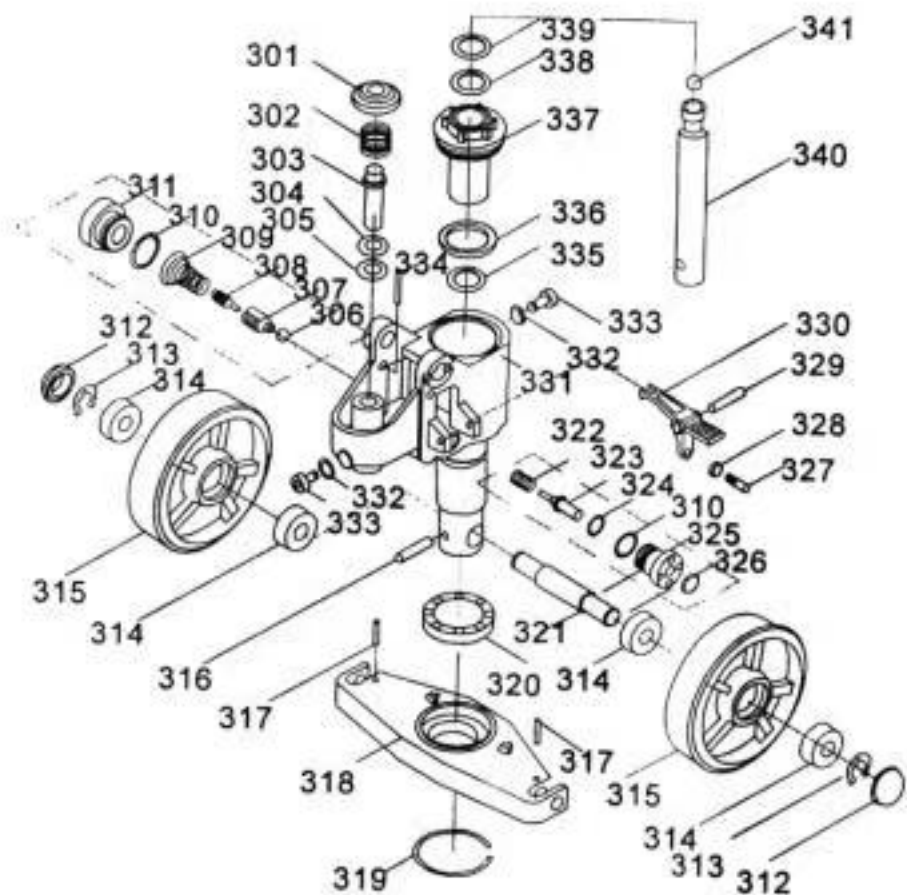

Figure 6